



iLP/iLP-V

Vertical In-Line Pump



Springs of Living Water



D

iLP/iLP-V

용도 Application	D 01
특징 Features	D 01
호칭 Model Designation	D 01
표준 사양 Standard Specification	D 01
인버터 부착형 인라인펌프 iLP-V Inverter Type Inline Pump, iLP-V	D 02
선정도 Selection Chart	D 03
조립 단면도 Sectional Drawing	D 05
구조 특징 Structural Features	D 08
외형도 & 외형 치수표 Outline Drawing & Dimension 60Hz [FIGURE I]	D 09
외형도 & 외형 치수표 Outline Drawing & Dimension 60Hz [FIGURE II]	D 10
외형도 & 외형 치수표 Outline Drawing & Dimension 60Hz [FIGURE III]	D 11
외형도 & 외형 치수표 Outline Drawing & Dimension 60Hz [FIGURE IV]	D 13
iLP-S	
특징 Features	D 15
응용분야 Application	D 17
센서리스 제어방법 Control Method	D 18

용도 Application



특징 Features

- | | |
|---|---|
| <ul style="list-style-type: none"> 01. Compact한 구조로 효율적인 설치공간 활용과 장기간 운전성능 보장 02. 고온, 고압에 운전이 가능한 메카니칼 씰 장착 03. 펌프와 전동기 축 분할구조로 설계하여 부품의 분해 및 조립 용이 단, 구경 32mm 이하, iLP40-115 모델은 펌프와 모터 축 일체형 구조 04. 배관의 해체없이 분해, 점검이 가능하며 회전차 및 메카니칼 씰 교체 가능한 구조 05. GT(Group Technology)기법을 도입, 부품의 호환성을 극대화시킨 구조 06. 전동기 취부가 끼워 맞춤 공차로 취부되므로 축심 일치가 간단해지며 설치, 유지 보수 작업 용이 07. 베이스 플레이트를 이용하여 지상설치 가능 (Option) | <ul style="list-style-type: none"> 01. Space efficiency and assurance of durability in terms of performance due to compact structure 02. Mechanical seal that can be operated under high-temperature and high-pressure condition 03. Easy to disassemble and assemble parts by designing with a split structure of pump and motor shaft For models below 32mm, iLP40-115, the pump and motor shaft are integrated 04. Structure that disassembles, inspects and replaces impeller and mechanical seal without disassembling the pipe 05. Part compatibility maximized by introducing GT(Group Technology) methodology 06. Simple shaft core alignment and easy installation and maintenance as the motor is tolerance fit 07. Ground installable using the base plate (Option) |
|---|---|

호칭 Model Designation

iLP 200-315

펌프 모델명 <h2>iLP</h2> Model Name	흡, 토출구경 <h2>200</h2> Suction and Discharge Diameter [mm]	회전차 공칭외경 <h2>315</h2> Impeller Nominal Diameter [mm]
--------------------------------------	--	--

표준 사양 Standard Specification

항목 Category	2P 모터 적용		4P 모터 적용
	구경 32, 40*	구경 40 ~	청수 Clean Water (pH 5.8 ~ 8.6) 0 ~ 140°C
취급액 Applicable Liquid	청수 Clean Water (pH 5.8 ~ 8.6) 0 ~ 120°C	청수 Clean Water (pH 5.8 ~ 8.6) 0 ~ 100°C	청수 Clean Water (pH 5.8 ~ 8.6) 0 ~ 140°C
최대 허용 압력 Maximum Allowable Pressure	25 bar	16 bar(Option : 25 bar)	
구조 Structure	회전차 Impeller	클로즈형 Closed Type	
	축봉타입 Shaft seal	Mechanical Seal (SiC/Carbon)	
회전방향 회전 방향	축 Shaft	펌프 및 모터 축 일체 Integral shaft(Pump & Motor)	펌프 및 모터 축 분할 Separate pump from motor shaft
	회전 방향	CW (구동기 축에서 펌프를 바라보았을 때) (From the Motor Side to the Pump)	
흡, 토출 플랜지 카플링	흡, 토출 플랜지 Coupling	KS B 1511 20K, RF	KS B 1511 16K, RF
	케이싱 Casing	N/A	리지드 카플링 Rigid Coupling
재질 Material	회전차 Impeller	SSC13	GC250 (Option : GCD450, SSC13, etc.)
	축 Shaft	STS304 (Option : STS316, etc)	
모터 Motor	모터대 Motor stool	SSC13	GC250
	입력전압 Input Voltage	3-Phase/380V (Option : 220V, 440V), 1-Phase/220V	
인버터 운전범위 Inverter Operating Range	절연등급 Insulation Class	F	
	보호등급 Protection Class	IP 55	
		30Hz ~ 60Hz	

선택사양 Option

- 접액부 재질 (조립단면도의 사양란 참고)
- Rigid Spacer Coupling
- 순환 및 시스템 전용 인버터 부착
- 각종 계류, Drain/Vent 배관 구성
- 흡토출 플랜지 규격 (별도 문의요망)
- Base Plate, 도장사양 (요구사항)
- Material of the Liquid Contacting Part (Refer to the Specifications in the Sectional Drawing)
- Rigid Spacer Coupling
- Circulation and system-exclusive inverter
- Instrument, Drain/Vent Piping
- Suction and Discharge Flange Specification (Contact us)
- Base Plate, Painting (Requirement)

인버터 부착형 인라인펌프 iLP-V Inverter Type Inline Pump, iLP-V



주요기능

1. 128x64 Graphic의 LCD Display : 한글LCD 화면
2. 연동운전 : 5대의 인버터를 통신으로 연결 운전
3. 일정압/일정온도 제어, 차압/차온 제어
4. 순차 운전
5. 정전 후 자동 운전 복구
6. 주 Pump의 교번(교대) 운전
7. 고장 Pump Skip
8. 갈수 보호운전
9. 통신기능 (option)
10. 자가 진단

Major Features

1. 128X64 LCD Disply: Korean LCD
2. Interoperation: Interoperation of 5 Inverters via Communication
3. Consistent Pressure/Temperature Control, Differential Pressure/Temperature Control
4. Sequential Operation
5. Automatic Recovery After Power Failure
6. Rotational Operation of the Main Pump
7. Skipping of the Defective Pump
8. Water Shortage Protection
9. Communication (Option)
10. Self Diagnosis

제어항목 Control Items		내용 Description	Remark
입력사항 Input	입력전압 Input Voltage	3-Phase 342V ~ 528V	
	전압변동범위 Voltage Fluctuation Range	-15 ~ +10% (342V ~ 528V)	
	주파수변동범위 Frequency Fluctuation Range	-5 ~ +5% (20 ~ 60Hz)	
사용 환경 Operating Environment	온도 Temperature	-10°C ~ +40°C	
	상대습도 Relative Humidity	0 ~ 90%	
	진동 Vibration	0.6G (10-60Hz)	
콘트롤사양 Control Specification	콘트롤전원 Control Power	SPWM (Carrier Frequency 2-10Hz)	
	주파수해상도 Frequency Resolution	0.01Hz	
	토크특성 Torque Property	자동, 스타트 Auto, Start 150%(1.0Hz)	
	과부하 Overload	정격전류에 120%에서 1분간 120% of Rated Current, One Minute	
	가속/감속 시간 Acceleration/Deceleration Time	0.1 ~ 3600s / 개별 가감속 4가지 조합 가능 Respective Four Acceleration/Deceleration Combinations	
	V/F RATIO설정 V/F Ratio Setting	사용자 설정 가능 User Configuration	
	스톨 방지 레벨 Stall Prevention Level	20~150%, 설정가능 20~150%, Configurable	
운전사양 Operating Specification	키패드 Keypad	키패드 설정 Keypad Setting	
	주파수설정 Frequency Setting	0 ~ 5V / 0 ~ 10V / 4 ~ 20mA / 0 ~ 20mA	
		주파수 상한 / 하한 설정 Upper Limit/Lower Limit	
	다기능 출력 Multifunctional Output	3개의 SKIP 주파수 설정 3 Skip Frequencies	운전 상태 모니터 / 오류정보 표시 및 경고 Operating Status Monitor/ Error Display and Warning
보호기능 Protection	과전류 Overcurrent	정격 전류의 200% 200% of Rated Current	
	과부하 Overload	정격 전류의 120%(Delay:1분) 120% of Rated Current (Delay: 1minute)	
	모터 과부하 Motor Overload	Thermal Overload Relay	
	과전압 Overvoltage	DC-BUS 330-410V / DC-BUS 660-820V	
	순시 정전 Instantaneous Interruption	Speed Search에 의한 인버터 재가동(0~2초) Restart of the Inverter by Speed Search(0~2 Seconds)	
	과열 Overheating	써미스터 보호 방식 Thermistor Protection	
기타 제어 Other Control	통신 방식 Communication	감속 정지 / 자가-정지 / DC브레이크 / Carrier Deceleration Stop/Self-Stop / DC Brake/ Carrier	
		주파수 조절 가능(20kHz) Frequency Control (20kHz)	
		RS-485	

* 40 구경은 iLP40-115 모델만 해당
 ※ GC200, GC250 : Cast iron / GCD450 : Ductile / SSC13 : Stainless Steel Casting / STS304, STS316 : Stainless Steel Bar or Plate

iLP / iLP-V

Vertical In-Line Pump

2P 선정도 Selection Chart

4P 선정도 Selection Chart

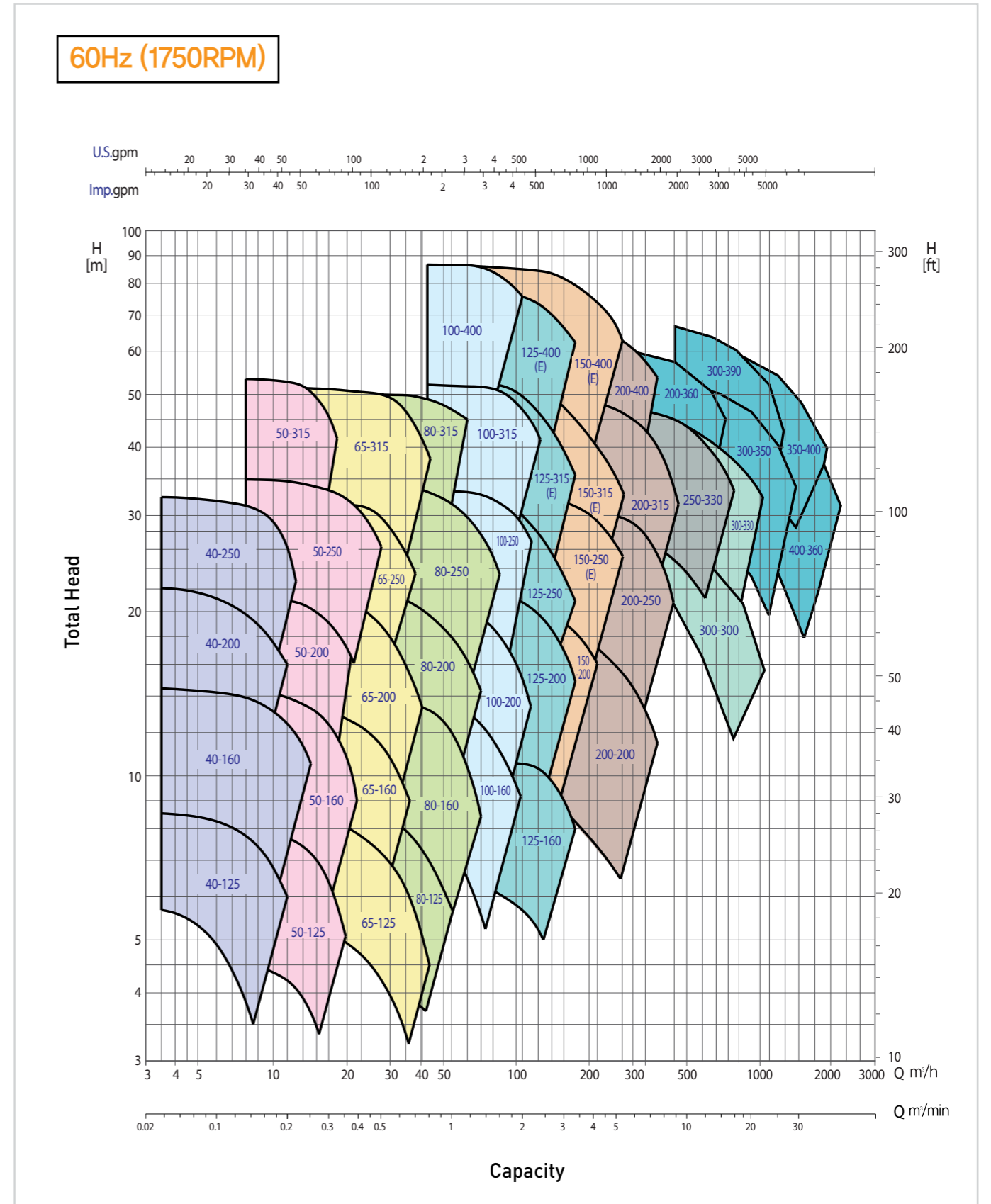
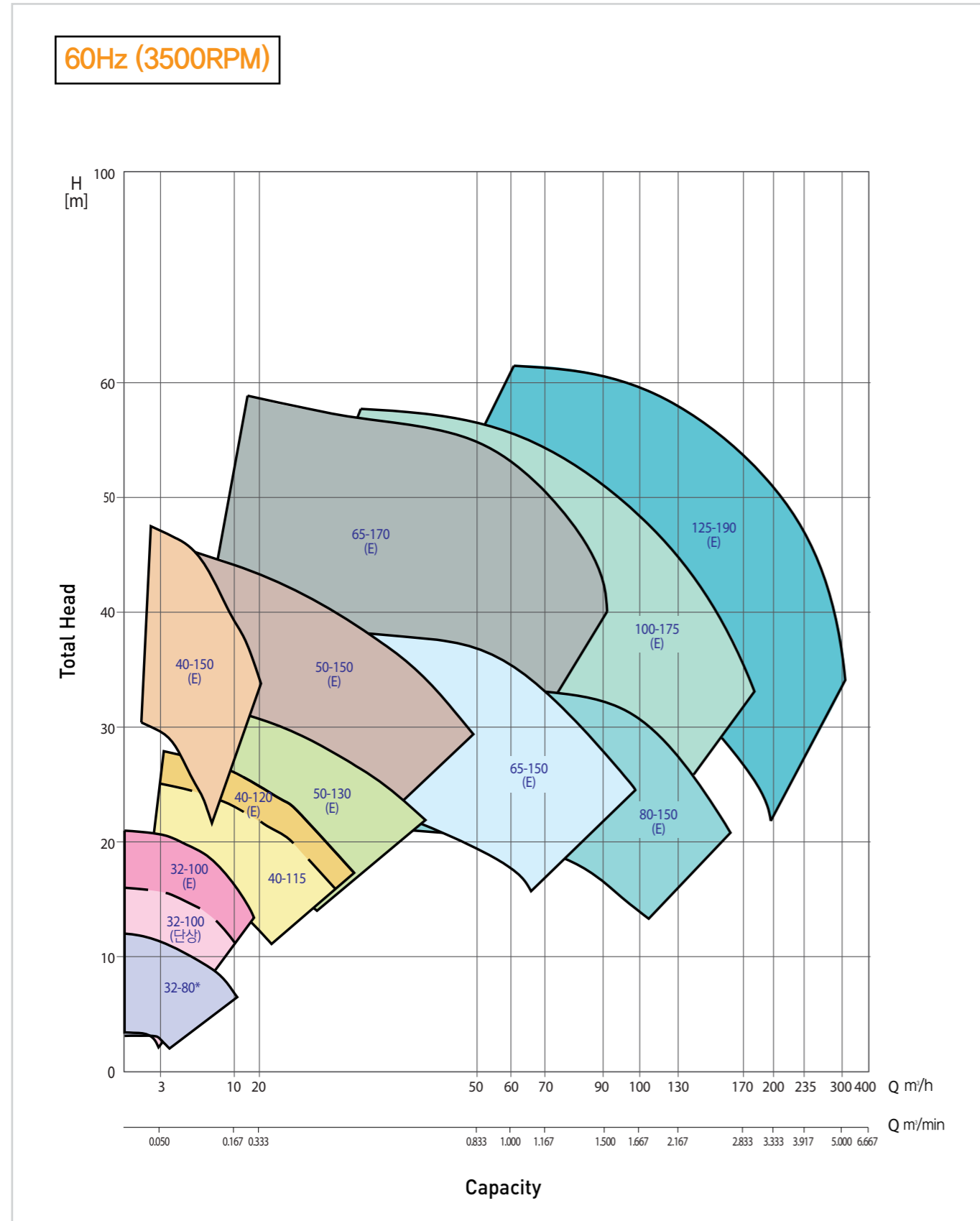

* iLP32-80, iLP32-100은 단상, 삼상 모델이 있으며, 동일한 성능임. 삼상 모델은 고효율 인증 모델임.

※ 인버터 부착형은 37kW까지 적용 가능. (45kW 이상은 판넬 타입을 권장함.)
Up to 37kW is applicable for the one with built-in inverter. (A panel type is recommended for 45kW or above.)

조립 단면도 Sectional Drawing

[2P iLP32, iLP40~115]

All Stainless

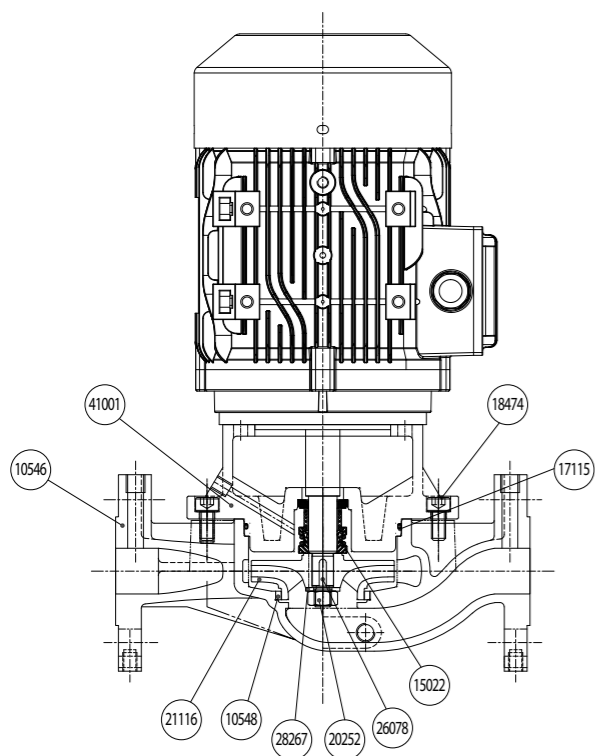

부품번호 Part No.	부품명 Part Name	표준재질 Standard Material	선택사양 Option
10546	Casing	SSC13	-
10548	Casing Ring	STS420J2	-
15022	Mechanical Seal	SiC/Carbon	-
20251	Shaft	STS304	-
21116	Impeller	SSC13	-
17115	O-Ring	VITON	-
18474	Hex Socket Bolt	STS304	-
26078	Impeller Key	STS304	-
28267	Washer	STS304	-
20252	Hex Nut	STS304	-
41001	Motor Stool	SSC13	-

[2P iLP40~125]

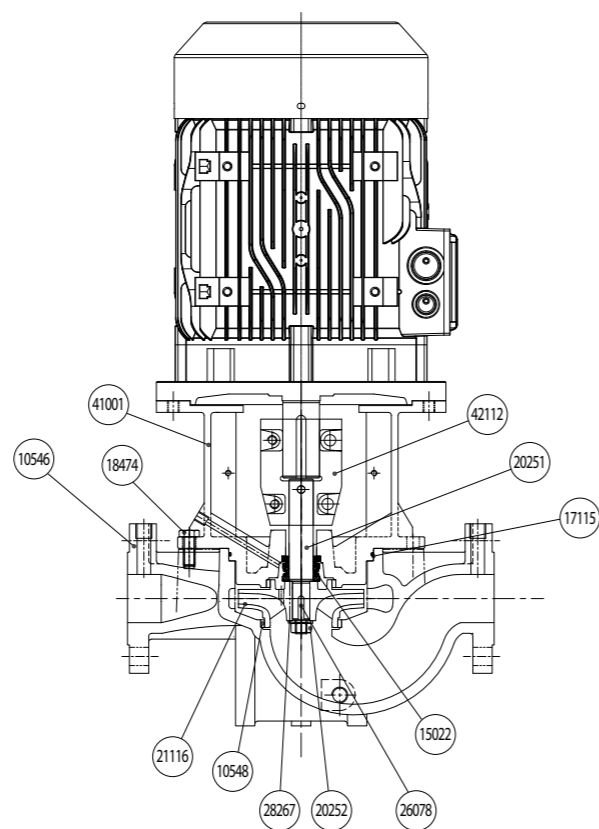

부품번호 Part No.	부품명 Part Name	표준재질 Standard Material	선택사양 Option
10546	Casing	GC250	GCD450
10548	Casing Ring	GC200	STS420J2
15022	Mechanical Seal	SiC/Carbon	-
20251	Shaft	STS304	-
21116	Impeller	GC200	SSC13
17115	O-Ring	VITON	-
18474	Hex Bolt	SM25C	-
26078	Impeller Key	STS304	-
28267	Washer	STS304	-
20252	Hex Nut	STS304	-
41001	Motor Stool	GC250	GCD450
42112	Rigid Coupling	GCD450	-

[iLP-V]

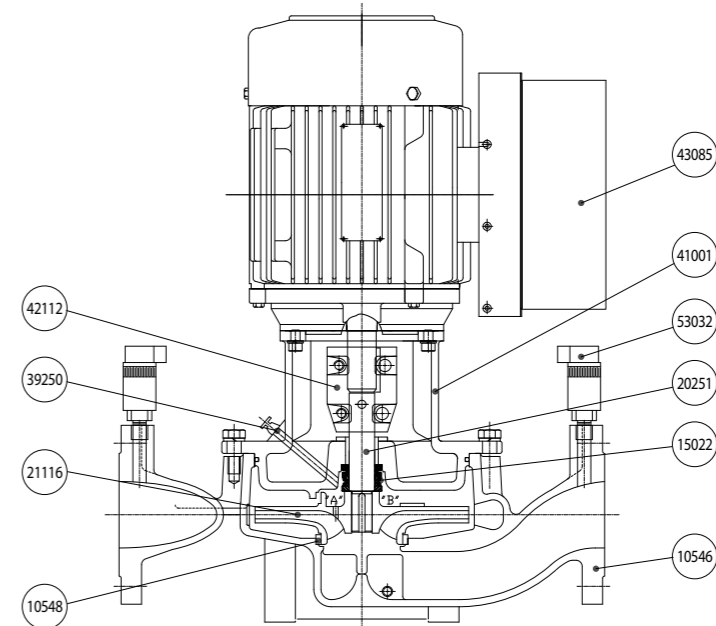

[4P iLP40~250]

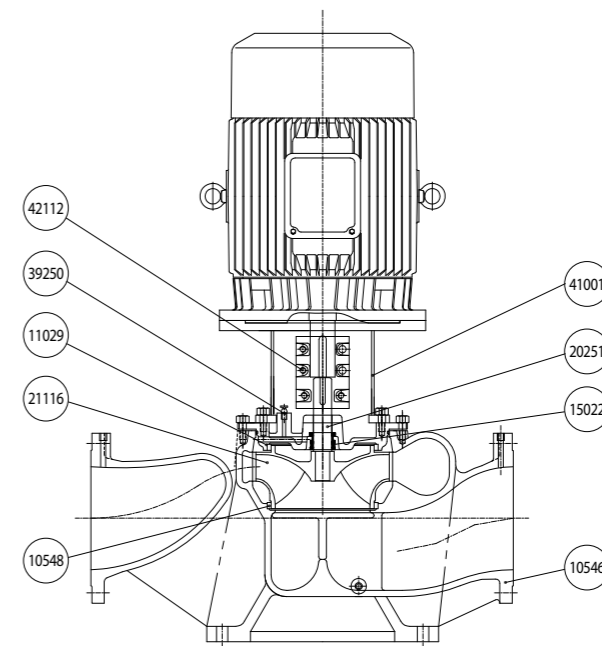

부품번호 Part No.	부품명 Part Name	표준재질 Standard Material	선택사양 Option	부품번호 Part No.	부품명 Part Name	표준재질 Standard Material	선택사양 Option
10546	Casing	GC250	GCD450/SSC13	39250	Air Vent	Brass	-
10548	Casing Ring	GC200	SSC13	41001	Motor Stool	SS275	-
11029	Stuffing Housing	GC250	-	42112	Rigid Coupling	GCD450	-
15022	Mechanical Seal	SiC/Carbon	-	43085	Inverter	-	-
20251	Shaft	STS304	STS316	53032	Pressure Transmitter	-	-
21116	Impeller	GC200	SSC13				

* 단, Stuffing Housing(11029)과 Motor Stool(41001) 일체형인 경우 재질 GC250 적용함.

iLP / iLP-V

Vertical In-Line Pump

조립 단면도 Sectional Drawing

[4P iLP300 이상]

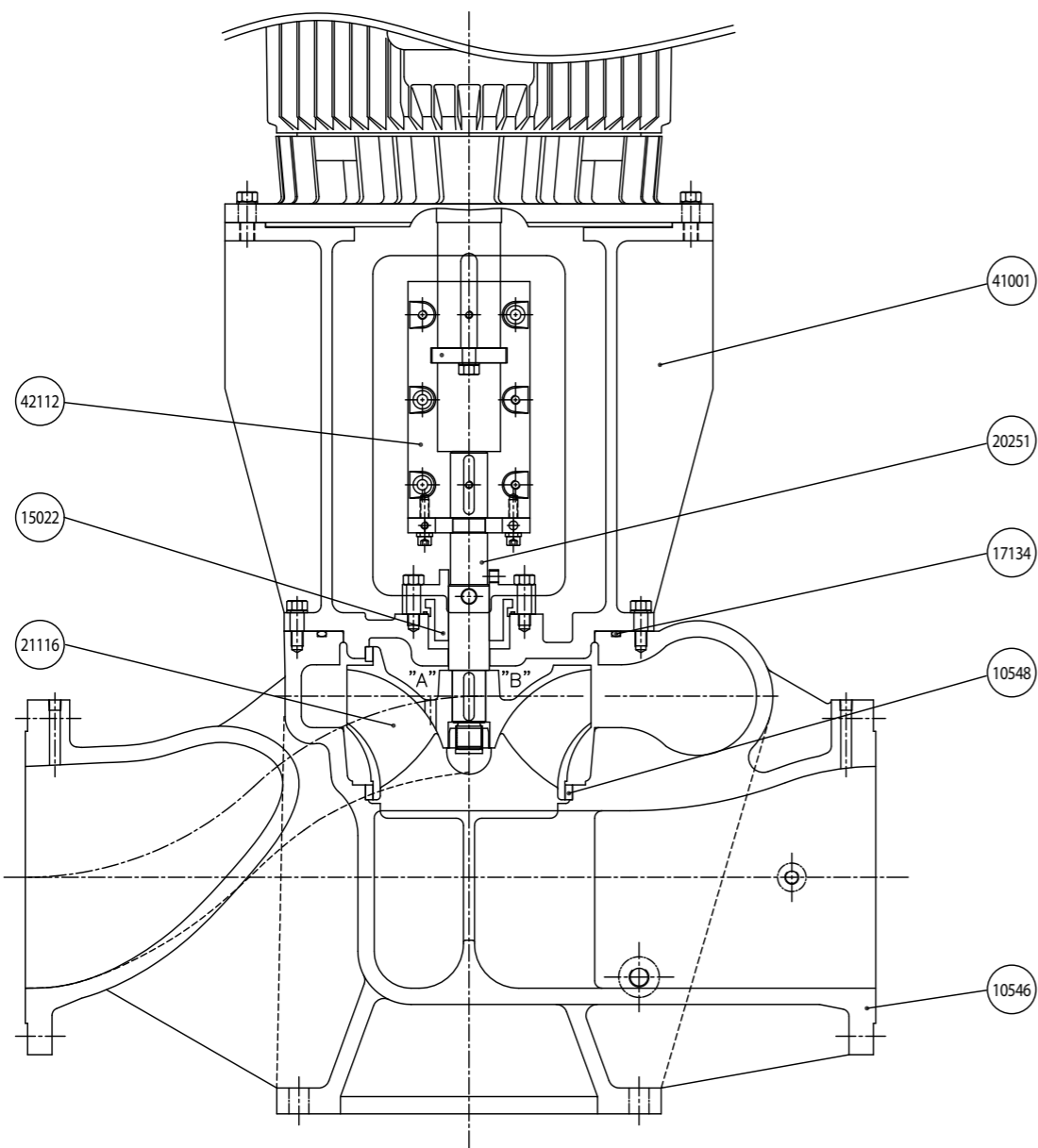

부품번호 Part No.	부품명 Part Name	표준재질 Standard Material	선택사양 Option	부품번호 Part No.	부품명 Part Name	표준재질 Standard Material	선택사양 Option
10546	Casing	GC250	GCD450/SSC13	20251	Shaft	STS304	STS316
10548	Casing Ring	GC200	SSC13	21116	Impeller	GC200	SSC13
15022	Mechanical Seal	SiC/Carbon	-	41001	Motor Stool	GC250	-
17134	O-Ring	NBR	-	42112	Rigid Coupling	GCD450	-

* Stuffing Housing(11029)과 Motor Stool(41001) 분리형 적용 모델 하기 참조
 - iLP200-360, iLP300-350, iLP300-390, iLP350-400, iLP400-360
 - 상기 기종의 Stuffing Housing 재질은 GC250, Motor Stool 재질은 SS275 임.

구조 특징 Structural Features

[2P iLP32, iLP40~115]

All Stainless

펌프 케이싱 Pump Casing

- 흡, 토출 플랜지
Suction and Discharge Flange
: KS B 1511 20K
- 표준재질 Standard Material
: SSC13

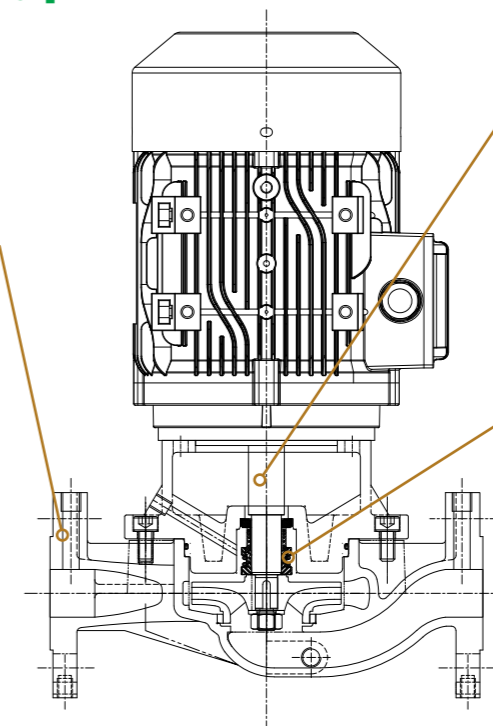

SHAFT

- 모터 & 펌프 축 일체형
Compact Size

SHAFT MECHANICAL SEAL

- 허용압력 Allowable Pressure : 25 bar
- 온도 Temperature : 0 ~ 120 °C
- 형식 Type : Elastomer Bellows
- 재질 Material : SiC/Carbon, Viton, EPDM STS316

[iLP40~300]

국제 IE3 프리미엄전동기 IE3 efficiency motor accredited by International IEC Standard

모터대 Motor stool

- 분할 리지드 커플링 및 커버
Partitioned rigid coupling and cover
- 에어벤트 스크류 Air bent screw
: PT 1/8", Brass
- O-RING : NBR

펌프 케이싱 Pump Casing

- 흡, 토출 플랜지
Suction and Discharge Flange
: KS B 1511 16K / 20K
- 표준재질 Standard Material
: GC250
- 최적으로 및 고압 신뢰성 설계
Design that ensures optimal flow path
and reliability under high pressurer

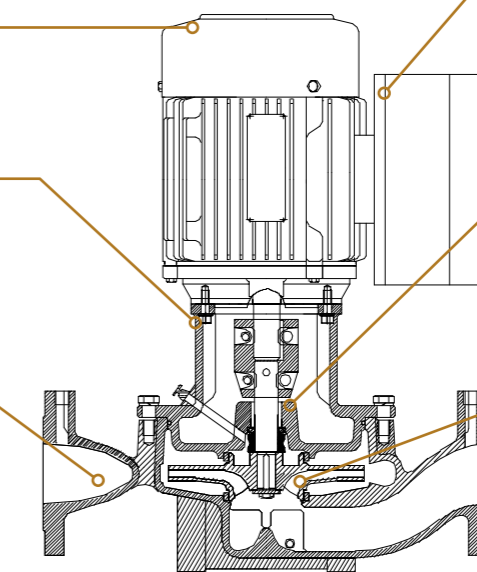

INVERTER

- 순환시스템 전용 인버터
Inverter dedicated to circulation system
- 한글 LCD
LCD in Korean language

SHAFT MECHANICAL SEAL

- 허용압력 Allowable Pressure : 25 bar
- 온도 Temperature : 0 ~ 140 °C
- 형식 Type : Elastomer Bellows
- 재질 Material : SiC/Carbon, Viton, STS316

회전차 및 웨어링 Impeller and wearing

- 최적의 회전차 설계 및 고효율 실현
Optimal Impeller design and high efficiency
- 회전차 재질 Impeller Material
: GC200, CAC406, SSC13
- 웨어링 재질 Wearing Material
: GC200, CAC406
- 축추력 안정성 설계
Design that ensures axial trust

iLP / iLP-V

Vertical In-Line Pump

외형도 & 외형 치수표 Outline Drawing & Dimension

60Hz

[FIGURE I]

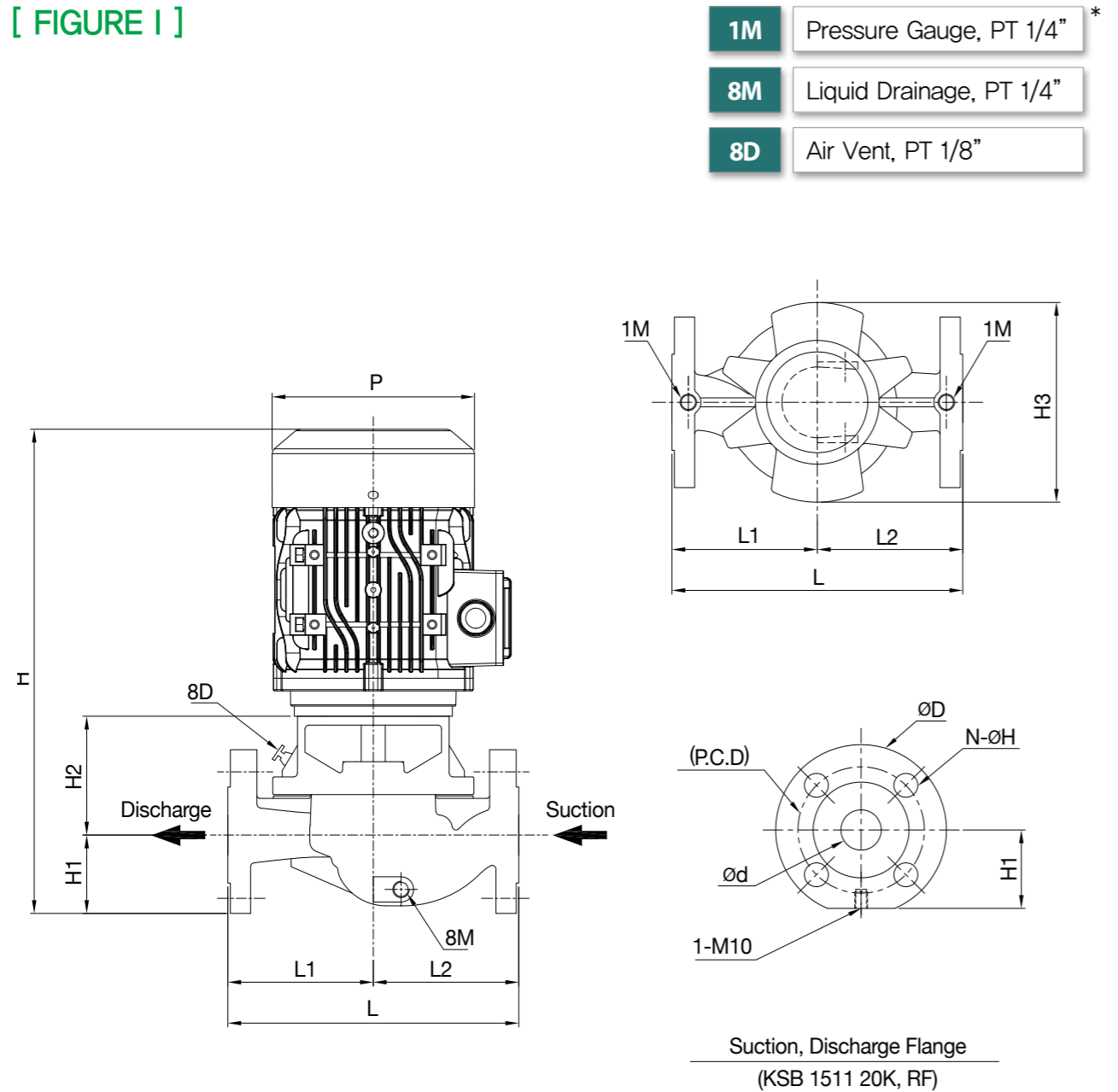

No.	Model	Phase	Pole	Power [kW]	Motor Frame	Fig.	Dimension (mm)													중량 Weight (kg)	
							Ød	H	H1	H2	H3	L	L1	L2	ØP	1M	N-ØH	Flange	P.C.D		D
1	iLP32-80	단상	2P	0.4	80M	I	32	383	62	94	158	230	115	115	160	PT1/4"	4-19	KSB 1511 20K RF	100	135	46
2	iLP32-80	상상	2P	0.75	80M	I	32	383	62	94	158	230	115	115	160	PT1/4"	4-19	KSB 1511 20K RF	100	135	46
3	iLP32-100	단상	2P	0.75	90L	I	32	438	62	102.5	184	290	145	145	180	PT1/4"	4-19	KSB 1511 20K RF	100	135	54
4	iLP32-100	상상	2P	0.75	90L	I	32	438	62	102.5	184	290	145	145	180	PT1/4"	4-19	KSB 1511 20K RF	100	135	54
5	iLP32-100	상상	2P	1.5	90L	I	32	438	62	102.5	184	290	145	145	180	PT1/4"	4-19	KSB 1511 20K RF	100	135	54
6	iLP40-115	상상	2P	2.2	90L	I	40	489	115	101	203	350	165	185	180	PT3/8"	4-19	KSB 1511 20K RF	105	140	58

* iLP40-115 모델의 1M: PT3/8", 8M: PT3/8", 8D: PT1/8" 임, 플랜지 형상은 FIGURE II 참조.

60Hz

[FIGURE II]

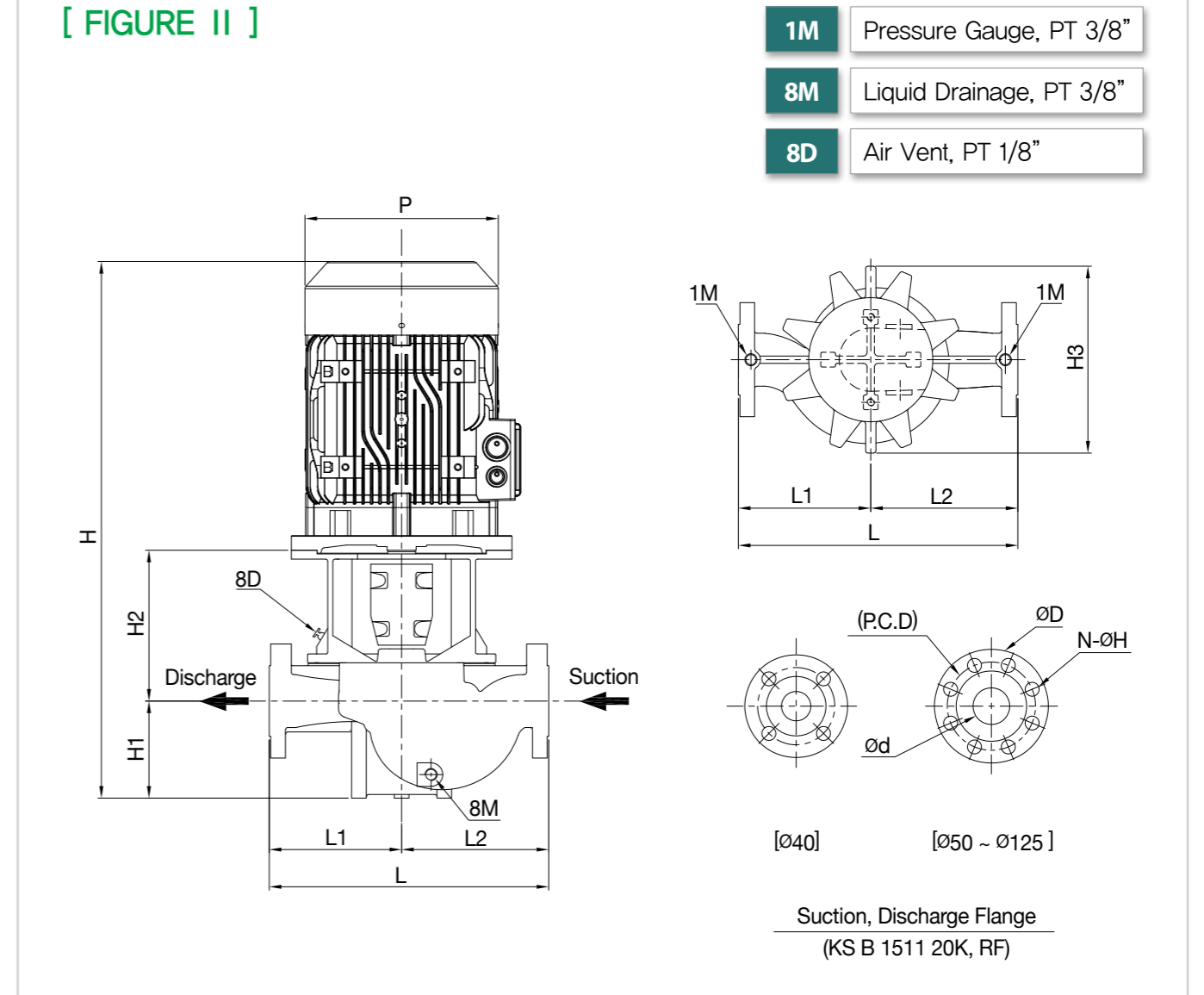

No.	Model	Pole	Power [kW]	Motor Frame	Fig.	Dimension (mm)													중량 Weight (kg)		
						Ød	H	H1	H2	호성 모터	H3	L	L1	L2	ØP	1M	N-ØH	Flange		P.C.D	D
1	iLP40-120	2P	1.5	90L	II	40	580	115	151	314	203	350	165	185	180	PT3/8"	4-19	KSB 1511 20K RF	105	140	75
2	iLP40-120	2P	3.7	112M	II	40	621	115	171	335	203	350	165	185	232	PT3/8"	4-19	KSB 1511 20K RF	105	140	106
3	iLP40-150	2P	1.5	90L	II	40	577	112	151	314	230	360	175	185	180	PT3/8"	4-19	KSB 1511 20K RF	105	140	66
4	iLP40-150	2P	2.2	90L	II	40	577	112	151	314	230	360	175	185	180	PT3/8"	4-19	KSB 1511 20K RF	105	140	66
5	iLP40-150	2P	3.7	112M	II	40	618	112	171	335	230	360	175	185	232	PT3/8"	4-19	KSB 1511 20K RF	105	140	87
6	iLP50-130	2P	3.7	112M	II	50	642	132	175	335	254	380	180	200	232	PT3/8"	8-19	KSB 1511 20K RF	120	155	123
7	iLP50-130	2P	5.5	132S	II	50	713	132	205	376	254	380	180	200	263	PT3/8"	8-19	KSB 1511 20K RF	120	155	164
8	iLP50-150	2P	3.7	112M	II	50	643	135	173	335	261	405	190	215	232	PT3/8"	8-19	KSB 1511 20K RF	120	155	98
9	iLP50-150	2P	5.5	132S	II	50	714	135	203	376	261	405	190	215	263	PT3/8"	8-19	KSB 1511 20K RF	120	155	98
10	iLP50-150	2P	7.5	132S	II	50	714	135	203	376	261	405	190	215	263	PT3/8"	8-19	KSB 1511 20K RF	120	155	133
11	iLP65-150	2P	5.5	132S	II	65	739	143	220	376	302	459	209	250	263	PT3/8"	8-19	KSB 1511 20K RF	140	175	194
12	iLP65-150	2P	11	160M	II	65	886	143	265	478	302	459	209	250	263	PT3/8"	8-19	KSB 1511 20K RF	140	175	271
13	iLP65-170	2P	5.5	132S	II	65	752	150	226	376	320	470	220	250	263	PT3/8"	8-19	KSB 1511 20K RF	140	175	152
14	iLP65-170	2P	7.5	132S	II	65	752	150	226	376	320	470	220	250	263	PT3/8"	8-19	KSB 1511 20K RF	140	175	152
15	iLP65-170	2P	11	160M	II	65	896	150	268	478	320	470	220	250	263	PT3/8"	8-19	KSB 1511 20K RF	140	175	215
16	iLP65-170	2P	15	160M	II	65	896	150	268	478	320	470	220	250	263	PT3/8"	8-19	KSB 1511 20K RF	140	175	215
17	iLP80-150	2P	5.5	132S	II	80	763	111	276	376	314	460	230	230	263	PT3/8"	8-23	KSB 1511 20K RF	160	200	210
18	iLP80-150	2P	7.5	132S	II	80	763	111	276	376	314	460	230	230	263	PT3/8"	8-23	KSB 1511 20K RF	160	200	210
19	iLP80-150	2P	11	160M	II	80	907	111	318	478	314	460	230	230	263	PT3/8"	8-23	KSB 1511 20K RF	160	200	290
20	iLP80-150	2P	15	160M	II	80	907	111	318	478	314	460	230	230	263	PT3/8"	8-23	KSB 1511 20K RF	160	200	290
21	iLP100-175	2P	22	180M	II	100	1016	175	273	568	392	560	260	300	317	PT3/8"	8-23	KSB 1511 20K RF	185	225	308
22	iLP100-175	2P	30	180L	II	100	1054	175	273	606	392	560	260	300	356	PT3/8"	8-23	KSB 1511 20K RF	185	225	331
23	iLP125-190	2P	37	200L	II	125	1167	138	359	670	412	595	295	300	407	PT3/8"	8-25	KSB 1511 20K RF	225	270	504
24	iLP125-190	2P	45	200L	II	125	1167	138	359	670	412	595	295	300	407	PT3/8"	8-25	KSB 1511 20K RF	225	270	504

* 상기 표의 iLP 모델은 모두 삼상 모델임. * 상기 표의 치수 및 중량은 호성 모터 적용 기준임

